

FAO Classification of Fishery Vessel types

Leela Edwin

Central Institute of Fisheries Technology

P.O. Matsyapuri, Cochin – 682 029

E-mail: leela@cift.ker.nic.in

The Food and Agriculture Organisation (FAO) of the UN has published a technical document under the name 'Definition and Classification of Fishery Vessel Types' (FAO Fisheries Technical Paper - 267) The term **fishery vessels** used in this paper comprises mobile floating objects of any kind and size operating in fresh water, brackish water and marine areas, used for catching, transporting, landing, preserving and / or processing of fish, shell fish and other aquatic animals (excluding whales) residues and plants. Also included are vessels performing other functions related to fisheries such as supplying, protecting, rendering assistance or conducting research or training. The term **fishing vessels** is used to distinguish fishery vessels engaged in catching operations. The term **non-fishing vessels** cover the remaining fishery vessels. The basic criterion used for the classification of fishery vessels is the gear used for catching fish or other aquatic organisms. The characteristics used for distinguish the various types and classes of fishing vessels are

- the general arrangement and deck layout
- position of the bridge or wheel house
- the fishing equipment used
- method of fish preservation and processing

The size of the vessels, expressed as gross tonnage or length is used for subdividing vessel types into classes. This strictly statistical subdivision is often replaced in practical applications as large, medium sized and small vessels. This subdivision corresponds approximately to the area of operation of the vessels – large fishery vessels often operate in open seas, medium sized vessels in the EEZ marine areas and small sized in coastal and sheltered marine and brackish water. From the variety of fishery vessel types operating, the world over, the most representative ones have been selected for description in the FAO classification. The major categories of fishing vessels are described as given

Fishing vessels

1. Trawlers

These vessels use trawls as fishing gear and are provided with engines of sufficient power to tow the net at the appropriate trawling speed. They are fitted with trawl winches and equipment necessary to haul the net onboard and lift the cod end over the deck. Depending on the area of operation and the trawl used trawlers range in size from open boats with inboard motors up to large freezer and factory trawlers. Trawling may be by using two boats (pair trawling) or by a single boat.

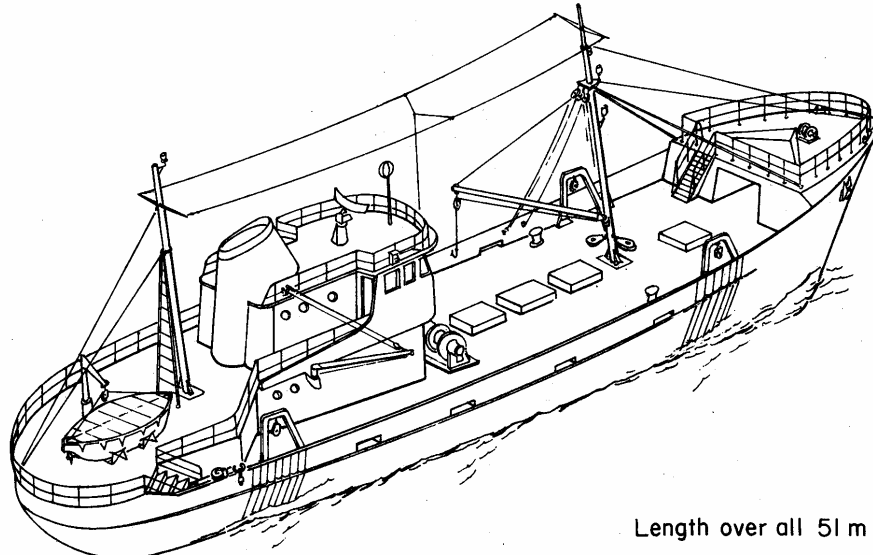

Length over all 51 m

1.1 Side trawlers

On side trawlers the trawl is set on the side and the warps pass through blocks hanging from two gallows, one forward and one aft. Usually the superstructure and wheel house are placed aft, the fish hold is situated amidships and the trawl winch transversally at the front of the superstructure. When the vessel is not trawling, the otterboards are stored between the gallows and the bulwark.

1.2 Stern trawlers

On these vessels the warps are led from the trawl winch through various lead blocks to the after deck and over the stern. The wheel house or bridge is usually situated in the forward part of the vessel. Medium sized and large stern trawlers are often fitted with a stern ramp, on which the trawl is hauled on to the deck. On small vessels a stern roller is used to reduce friction when shooting and hauling up the trawl. The trawl winch is placed transversely usually behind the wheel house. On small vessels the fish hold is situated amidships and on medium sized and large stern trawlers in the forward part of the vessel.

In wet fish trawlers fish is kept in the hold in the fresh / wet condition. Wet fish trawlers therefore operate usually in areas not too far from their landing place. The majority of small trawlers and some medium sized trawlers are not equipped with refrigerating plants but many of them have insulated fish holds and carry ice to preserve fish.

1.3 Freezer trawlers

These are vessels on which the fish is preserved by freezing. Freezer trawlers are outfitted with refrigerating plant and freezing equipment. The holds are insulated and refrigerated.

1.4 Factory trawlers

These are generally large stern trawlers equipped with processing plants including mechanised gutting and filtering equipment with accompanying freezing installation, fish oil,

fish meal and sometimes canning plants. Separate holds are provided for each of the products. Extensive superstructure are typical features of factory trawlers.

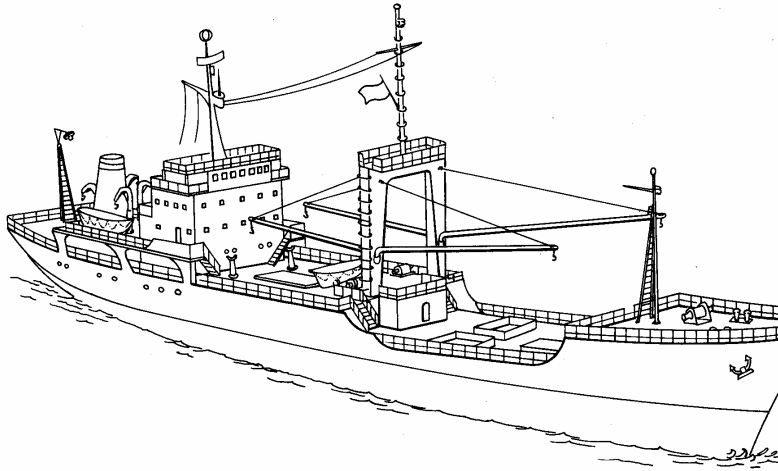

1.5 Outrigger trawlers

These have strong outrigger booms to tow the fishing gear. These outriggers are usually fastened to the mast and extend out from the sides of the vessel each towing one or two trawls. These are used for shrimp trawling. Another method using outrigger, is the use of very heavy outrigger and gear for towing trawls fitted with beams and heavy bottom gear which is principally used for the capture of flat fish.

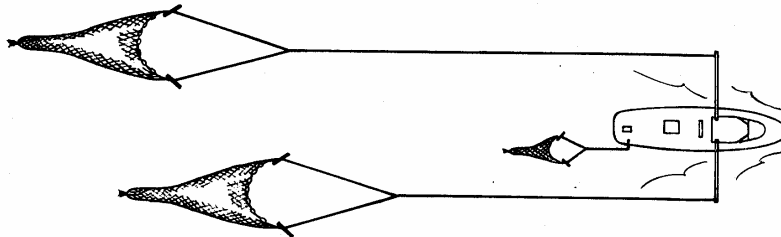

2. Seiners

These vessels use surrounding and seine nets. They comprise a large group appearing in all sizes, ranging from open boats and canoes up to large ocean going vessels. They are used for catching pelagic species. The equipment on board seiners consists usually of a power block and / or a net drum for hauling and stowing the net aboard and one or more winches for setting and hauling operation. On boats and canoes using small seine nets, all operations are generally performed by hand. A brailer attached to a derrick is provided for removing fish collected in the purse. Sometimes a pump is lowered into the pursed seine and the fish is pumped through a hose and a water separator on deck into the hold. To assist in fish school detection crow's nest is fitted on masts.

2.1. Purse seiners

Vessels using purse seines and equipped with pursing gallows and pursing winches for hauling the purse lines which close the net after setting. From the viewpoint of deck arrangement two main types of one boat purse-seiners can be distinguished

- the North American type and
- the European type

2.1.1. North American type purse – seiners

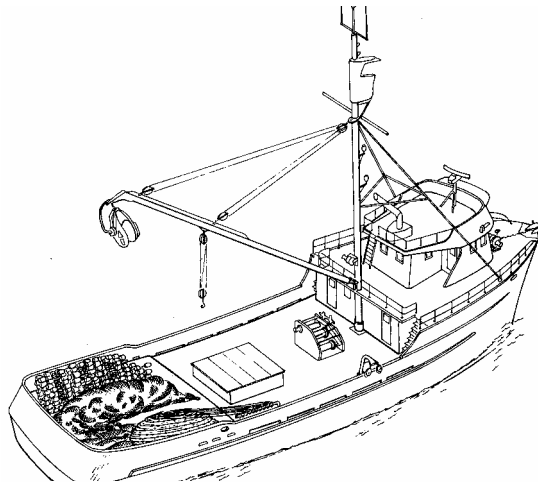

These seiners have the bridge and accommodation placed forward. The power block is slung from a derrick attached to the mast behind the wheel house. The winch is usually fitted to the parallel drums and is situated opposite the pursing gallows. The net is carried at the stern of the vessel.

2.1.2. European type purse seiners

This type of purse – seiners has the bridge and accommodation located aft. The fish hold is situated amidships. The net is carried on the upper deck and power block is fitted to the side of the bridge. The pursing winch is normally situated forward with the drums facing the pursing davit.

2.1.3. Tuna purse seiners

The vessels are large purse-seiners with the same general arrangement as the North American type, equipped to handle very large and heavy purse seines for tuna. They are normally equipped with a skiff. The deck equipment consists of a three drum purse – seine winch and a heavy boom and net. A crow's nest is placed at the top of the mast. The search for tuna schools is often carried out by a helicopter, for which a landing platform is provided.

2.1.4. Seine netters

The fishing area is surrounded by a net attached to very long ropes and the net is towed or dragged over the bottom. The nets used in this type of fishery are similar to light high opening bottom trawl but they use long length of seine rope spread out on the sea bed on each side of the net. Anchor seining (dragging), often known as Danish seining, uses an anchor which is buoyed and to which the first rope is attached.

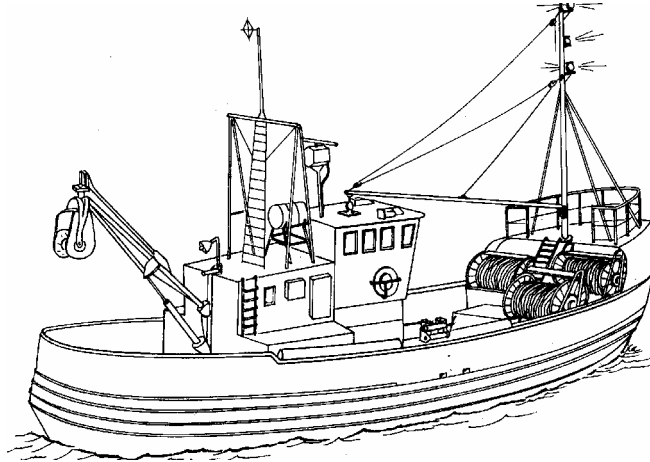

In Scottish seining, an anchor is not used, instead a combination of winch and propeller is used to simultaneously pull and close the gear. The vessel using this gear resemble the side trawler as almost all have the wheelhouse and accommodation aft. The ropes are coiled on hydraulic reels. A power block is fitted aft and net is hauled in there. The codend is lifted aboard on the side deck. A variation of the method is used by modern Japanese seiners in which the gear handling area is located aft and the wheel house forward.

3. Dredgers

These vessels use a dredge for collection of molluscs from the bottom. The vessel drags the gear and the power requirements can therefore be similar to those of a small trawler. A powerful water pump is necessary to operate the water jets of a mechanical dredge. For lowering and lifting of the dredge, derricks and winches are installed.

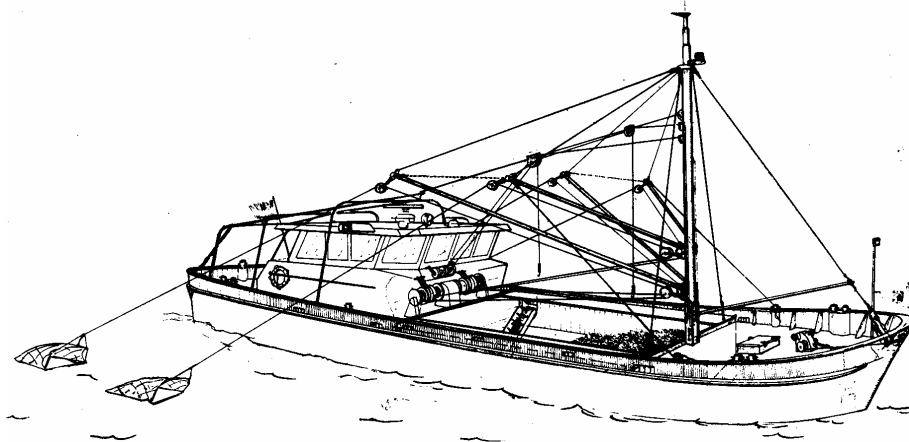

4. Lift Netters

These vessels are equipped for the operation of large lift nets, which were held out from the ships side and raised and lowered by means of outriggers. Sets of powerful lights for fish attraction are often used simultaneously with under water lights. The vessels have the bridge amidships and are fitted with derricks and winches for handling the lifting lines, outriggers and light booms.

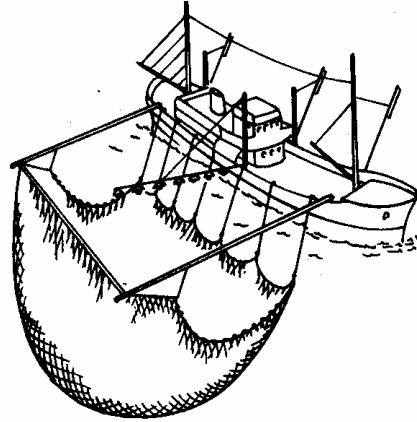

5. Gill netters

Gill nets can be operated from boats and canoes on inland waters and inshore, decked small vessels in coastal waters and from medium sized vessels fishing offshore. Small gill netters have their wheel house either aft or forward. In medium sized vessels the bridge is usually located aft. Drifters are often fitted with a steadying sail. On small vessels setting and hauling operations are by hand while in larger vessels hydraulic net haulers or net drums are used.

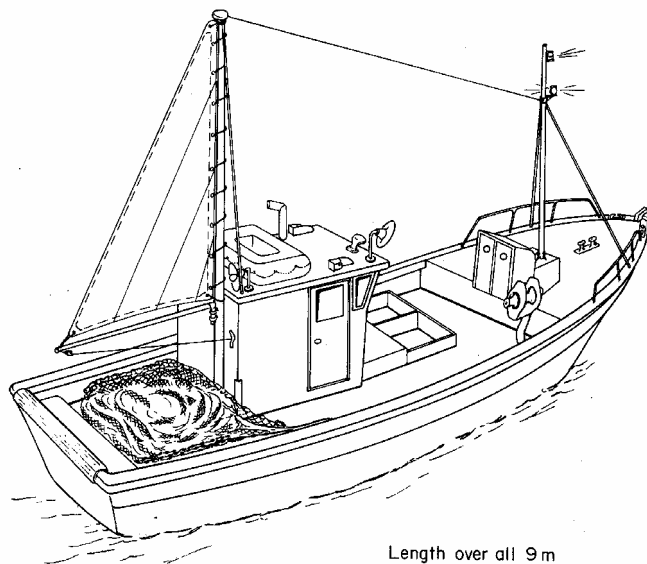

6. Trap setters

These include vessels setting traps and pots but also pound nets, fyke nets, stow nets and various kinds of barriers

6.1 *Pot vessels*

These vessels are used for setting pots for catching lobsters, crabs, crayfish and other similar species. Pot vessels range from open boats or large decked vessels. In open or partly open vessels the wheel house is placed forward. In the cockpit a suitable place to store pots is provided. A live well with seawater for transport of the catch is also situated in the cockpit. On small-decked pot vessels the wheelhouse is located either forward or aft and fish hold amidships. Larger pot vessels are equipped with derricks, cranes or darts for setting and hauling of pots. On smaller vessels mechanised pot haulers are fitted. Inshore pot vessels are often designed for relatively high speed because better prices are obtained for fresh catch.

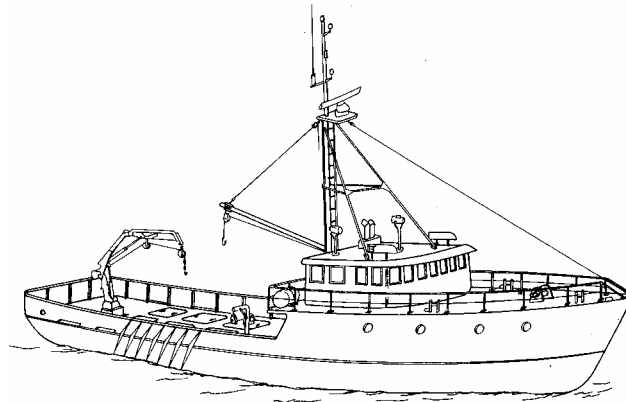

7. Liners

These vessels use lines and hooks with or without bait or line. Depending on the method of fishing with lines, area of operation and species to be caught, lines comprise vessels of all size classes.

7.1 *Handliners*

Handlines are operated from boats, canoes and other small vessels with out any special features for gear handling. Handlines can be set and hauled either manually or by mechanised reel fastened to the gunwale.

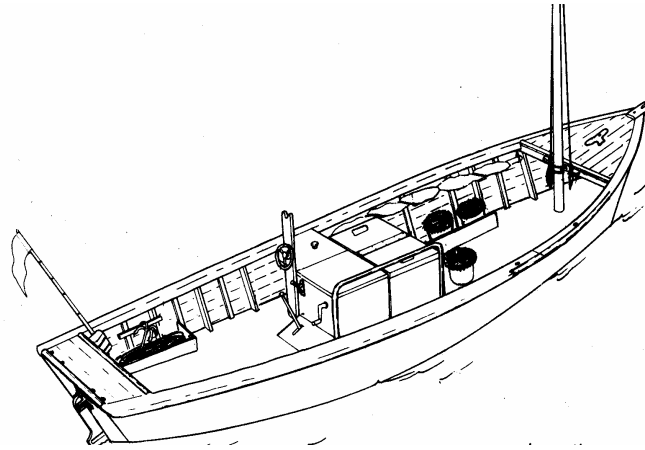

7.2 *Longliners*

Longliners can be operated from vessels of any size. In a typical arrangement the gear is hauled from the bow or from the side with a mechanical or hydraulic line hauler and the lines are set over the stern. The wheel house can be situated aft or forward but on larger vessels the bridge is generally placed aft. Automatic and semi – automatic systems are used in bigger boats to bait the hooks and to school and haul the lines.

7.3 *Tuna long liners*

Tuna long lines are usually operated from medium sized vessels. The line hauler is placed on the starboard side. A conveyor, to the aft deck ready for baiting and setting, then carries the long lines and the bouys. A baiting table and chute are located on the stern from where the lines are set. Typical equipment of a tuna longlines include brine freezing tanks in which tuna is preserved

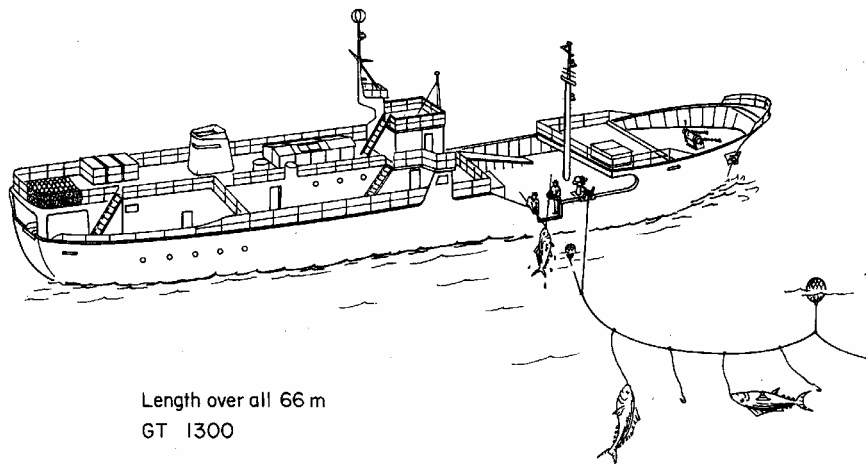

7.4 *Pole and line vessels*

These vessels are used for catching tuna and skipjack. Tanks with live bait and a water spray system for fish attraction are typical features of these vessels. Therefore this type

of fishing is also called live bait fishing. Two types of pole and line vessels can be distinguished, the Japanese type and the American type.

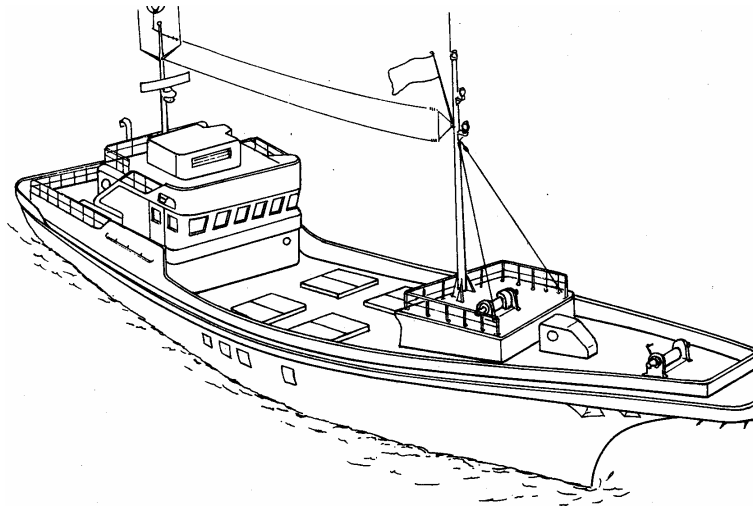

7.4.1 Japanese type pole and line vessels

On these vessels the fishermen stand at the railing on the forward part of the vessel and bridge is accommodated aft. The holds are placed in the middle part of the vessel.

7.4.2 American type pole and line vessels

On these vessels the platform for fishermen are located around the stern of the vessel with bait tanks on the deck aft and wheel house situated forward.

Trollers

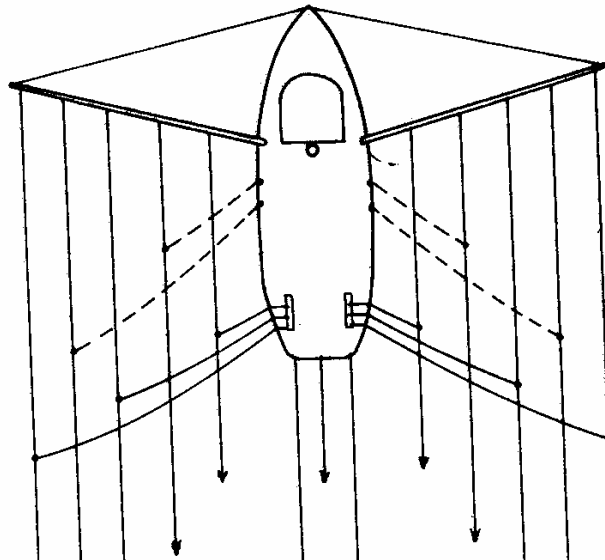

These vessels tow a number of lines fitted with lures. These are equipped for catching pelagic fish swimming close to trolling booms which are raised and lowered by topping lifts and fore and aft stays. According to the area of operation vessels may be laid out with wheel house and mast either forward or in the aft.

8. Vessels using pumps

During fishing operation the pump is lowered under the surface of water. Small fishes attracted by light from a lamp situated above the suction side of the pump are sucked and pumped with water onboard, where a fish water separator is installed.

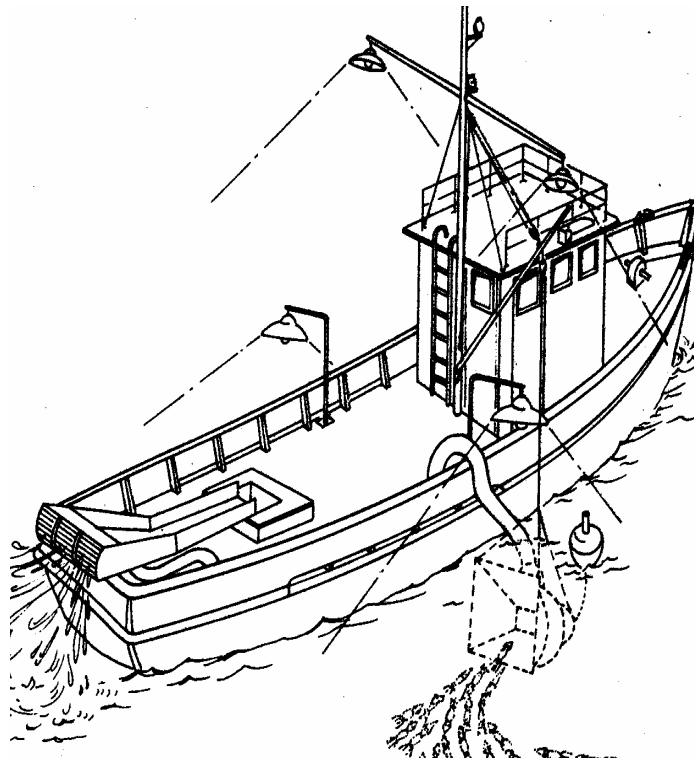

9. Multipurpose vessels

These vessels designed for alternative use of two or more fishing gear without major modification to the vessels outfit or equipments. Examples are gillnetter/ longliner, trawler/gillnetter, trawler / purse – seiners etc.

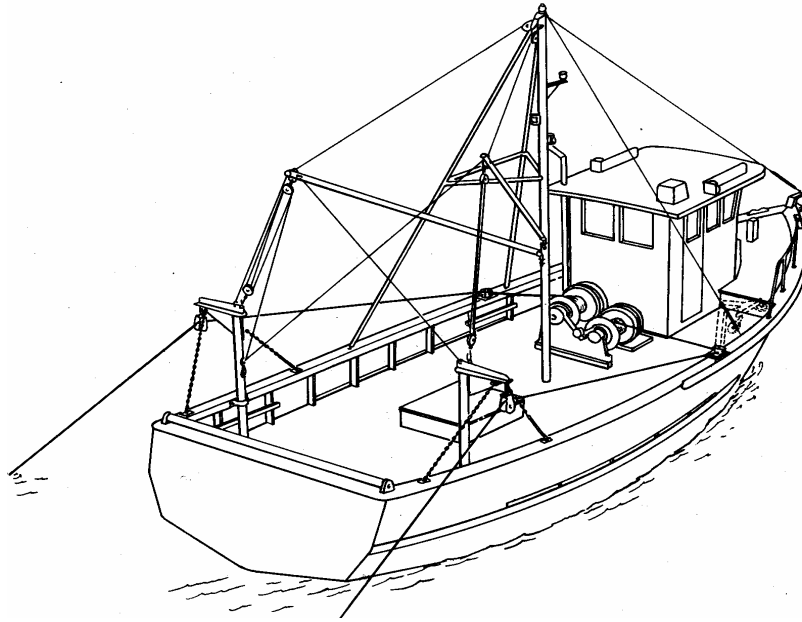

Non-fishing Vessels

10. Motherships

Mother ships provide fishing vessels at sea with supplies of fuel, provisions, freshwater and other consumable goods, transfer the catch from the vessels, process and preserve the fish, and render medical and social services to the crew. They also transport fish products in part.

Two types of such vessels are

10.1 Salted motherships

In these ships the fish is salted cured and put into barrels which are then stored in dry or refrigerated holds depending on the degree of salting. These vessels have the accommodation and bridge amidships and the fish holds fore and aft.

10.2 Factory motherships

Certain mother ships which carry on board small fishing vessels on arrival at fishing grounds the fishing vessels are launched for operation.

In these vessels fresh fish transferred at sea from fishing vessels under goes processing and preserving operations similar to these which are provided on factory trawlers. The engine room and the main part of the crew quarters are located aft. The bridge and the remaining part of the accommodation on larger vessels are selected forms.

10.3 Motherships with catching vessels aboard

This type of mother ships carries small tuna (15 m) long liners onboard. The long liners transfer the catches to the mother ship for processing, freezing and storing in refrigerated holds. The vessel has the engine room, accommodation and bridge situated aft.

10.4 Motherships for two- boat purse seining

These vessels carry two purse seiners on board. They are lowered when the vessel is approaching a fish school. The engine room and part of the accommodation are placed aft and the bridge with remaining quarters situated forward . The hold is situated between two superstructures.

11. Fish carriers

These are non – fishing vessels used exclusively for fish transport. They are large vessels with holds equipped for transport of fish and fish products. The superstructures are located aft ie amidships

12. Hospital Ships

These vessels render medical service to the crew. The space in the large superstructure are suitably arranged. It resembles a passenger ship.

13. Fishery Protection Vessels

These vessels perform the function of protection of the fishing grounds and surveillance of fishing vessels operating in territorial waters and in the EEZ.

14. Fishery Research Vessels

The size of these vessels depends on the area of operation and on research programmes. They are fitted for the operation of two or more fishing gear, special winches for taking samples and apparatus for measurement of environmental characteristics are provided.

15. Fishery Training Vessels

These vessels are used for training future fishermen in navigation, seamanship, fishing operation and fish handling. They are mostly typical fishing vessels with trainee accommodation.